



**INTEL<sup>®</sup>  
INNOVATION  
DAY**

**КЛИЕНТСКИЕ ПЛАТФОРМЫ**



# ОТКАЗ ОТ ОТВЕТСТВЕННОСТИ

МАТЕРИАЛЫ ПРЕДОСТАВЛЯЮТСЯ ПО ПРИНЦИПУ "КАК ЕСТЬ", БЕЗ КАКИХ-ЛИБО ЯВНЫХ ИЛИ ПОДРАЗУМЕВАЕМЫХ ГАРАНТИЙ, ВКЛЮЧАЯ, В ЧИСЛЕ ПРОЧЕГО, ГАРАНТИЙ В ОТНОШЕНИИ ИХ РЫНОЧНЫХ КАЧЕСТВ, НЕНАРУШЕНИЯ ПРАВ НА ИНТЕЛЛЕКТУАЛЬНУЮ СОБСТВЕННОСТЬ ИЛИ ПРИГОДНОСТИ К ИСПОЛЬЗОВАНИЮ В ТЕХ ИЛИ ИНЫХ КОНКРЕТНЫХ ЦЕЛЯХ. НИ ПРИ КАКИХ ОБСТОЯТЕЛЬСТВАХ КОРПОРАЦИЯ INTEL ИЛИ ЕЕ ПОСТАВЩИКИ НЕ НЕСУТ КАКОЙ-ЛИБО ОТВЕТСТВЕННОСТИ ЗА УЩЕРБ (ВКЛЮЧАЯ, В ЧИСЛЕ ПРОЧЕГО, УПУЩЕННУЮ ВЫГОДУ, ПОСЛЕДСТВИЯ ПРИОСТАНОВКИ ПРЕДПРИНИМАТЕЛЬСКОЙ ДЕЯТЕЛЬНОСТИ ИЛИ ПОТЕРЮ ДАННЫХ), ВЫТЕКАЮЩИЙ ИЗ ФАКТА ИСПОЛЬЗОВАНИЯ МАТЕРИАЛОВ, ЛИБО НЕВОЗМОЖНОСТИ ИХ ИСПОЛЬЗОВАТЬ, ЧТО РАСПРОСТРАНЯЕТСЯ И НА ТЕ СЛУЧАИ, КОГДА КОРПОРАЦИЯ INTEL БЫЛА ПРЕДУПРЕЖДЕНА О ВОЗМОЖНОСТИ НАНЕСЕНИЯ ТАКОГО УЩЕРБА. УЧИТЫВАЯ, ЧТО ЗАКОНОДАТЕЛЬСТВО, ДЕЙСТВУЮЩЕЕ В РЯДЕ ЮРИСДИКЦИЙ, НЕ ДОПУСКАЕТ ОГРАНИЧЕНИЯ ИЛИ ОТКАЗА ОТ ОТВЕТСТВЕННОСТИ ЗА ПОБОЧНЫЙ ИЛИ КОСВЕННЫЙ УЩЕРБ, ИЗЛОЖЕННОЕ ВЫШЕ ПОЛОЖЕНИЕ МОЖЕТ К ВАМ НЕ ОТНОСИТЬСЯ.

Корпорация Intel и ее поставщики не гарантируют точности или полноты текстовой или графической информации, ссылок и иного содержания материалов. Корпорация Intel вправе в любое время и без предварительного уведомления вносить любые изменения в указанные материалы, а равно и в продукцию, описанием которой они служат. Корпорация Intel не берет на себя каких-либо обязательств по обновлению материалов.

Информация о тестах производительности предназначена исключительно для специалистов в области компьютерной техники и программного обеспечения, обладающих соответствующими техническими знаниями. Покупателям при приобретении компьютерных систем или компонентов помимо производительности следует также учитывать и иные характеристики соответствующих систем и компонентов.

Тесты производительности и рейтинги измерены на конкретных компьютерных системах и/или компонентах и отражают приблизительную производительность продуктов корпорации Intel в единицах данных тестов. Любое отличие в аппаратных или программных компонентах или конфигурации может повлиять на результаты измерений. Дополнительную информацию по тестам производительности и производительности продуктов корпорации Intel можно узнать по адресу: [http://www.intel.com/performance/resources/benchmark\\_limitations.htm](http://www.intel.com/performance/resources/benchmark_limitations.htm)

Тесты третьих сторон: корпорация Intel не контролирует и не проверяет проведение и результаты тестов третьих сторон или публикации результатов тестов в интернете на которые есть ссылки в этой презентации. Корпорация Intel предлагает всем заинтересованным посетить указанные интернет-страницы и убедиться в том что данные тестов точно отражают производительность систем предлагаемых на рынке.



# INTEL® CORE™ PROCESSOR ADVOCACY



## Small screen 2-in-1s



**N-Series**  
Intel® UHD Graphics

Gemini Lake

## All-in-Ones



**Y-Series**  
Intel® UHD Graphics

Amber Lake

## 2-in-1s, Detachables



- Up to Intel® UHD Graphics for 720p gaming
- UHD resolution support

## Large screen 2-in-1s, Mainstream Notebooks Thin and Light



- Up to Intel® Iris™ Plus Graphics for 1080p gaming
- UHD resolution support

## U-Series

Intel® Iris™ Plus Graphics  
Intel® UHD Graphics

Kaby Lake-R/Whiskey Lake

## Performance All-in-Ones



- Up to Intel® UHD Graphics for 720p gaming
- 5K support
- UHD resolution support

## S-Series

Intel® UHD Graphics  
Mid-Range Discrete Graphics

Coffee Lake

## Mainstream Desktops



## Performance Notebooks



- >1080p gaming & premium VR experiences with H-series processors optimized for discrete graphics

## H-Series

Intel® UHD Graphics  
Intel® Core™ Processor with Radeon™ RX Vega M

Coffee Lake / Kaby Lake-G



## High-end Desktops

## X-Series

## S-Series 'K'

High-End Discrete Graphics

Coffee Lake





# NEW INTEL® CORE™ X-SERIES DESKTOP PROCESSORS

# NEW & FEATURED TECHNOLOGIES

- **NEW** Higher frequencies and increased cache for improved performance.
- **NEW** Solder Thermal Interface Material (STIM).
- **NEW** 44 processor PCIe lanes on all SKUs.
- Unlocked processors, up to 18 cores (8,10,12,14,16,18)
- Up to 36 threads, 24.75 MB cache, and 68 platform PCIe lanes.
- Intel® Turbo Boost Max technology 3.0.
- Intel® Optane™ SSD support.
- Thunderbolt™ 3 support.
- 4 channels DDR4 26663
- Intel® Hyper-Threading Technology



## Platform Details

Socket:  
• LGA 2066

Power:  
• 8C-18C: 165W<sup>5</sup>

### Platform I/O Support:

- 44 processor PCIe 3.0 lanes on all SKUs<sup>5</sup>
- 30 total chipset high-speed I/O lanes with increased port flexibility
  - Up to 24 PCIe 3.0 lanes
  - Up to 8 SATA 3.0 ports
  - Up to 10 USB 3.0 ports
- Up to 3 Intel® RST PCIe 3.0 x4 storage support
- Supports Intel® Ethernet Connection I219 (Jacksonville LAN PHY)

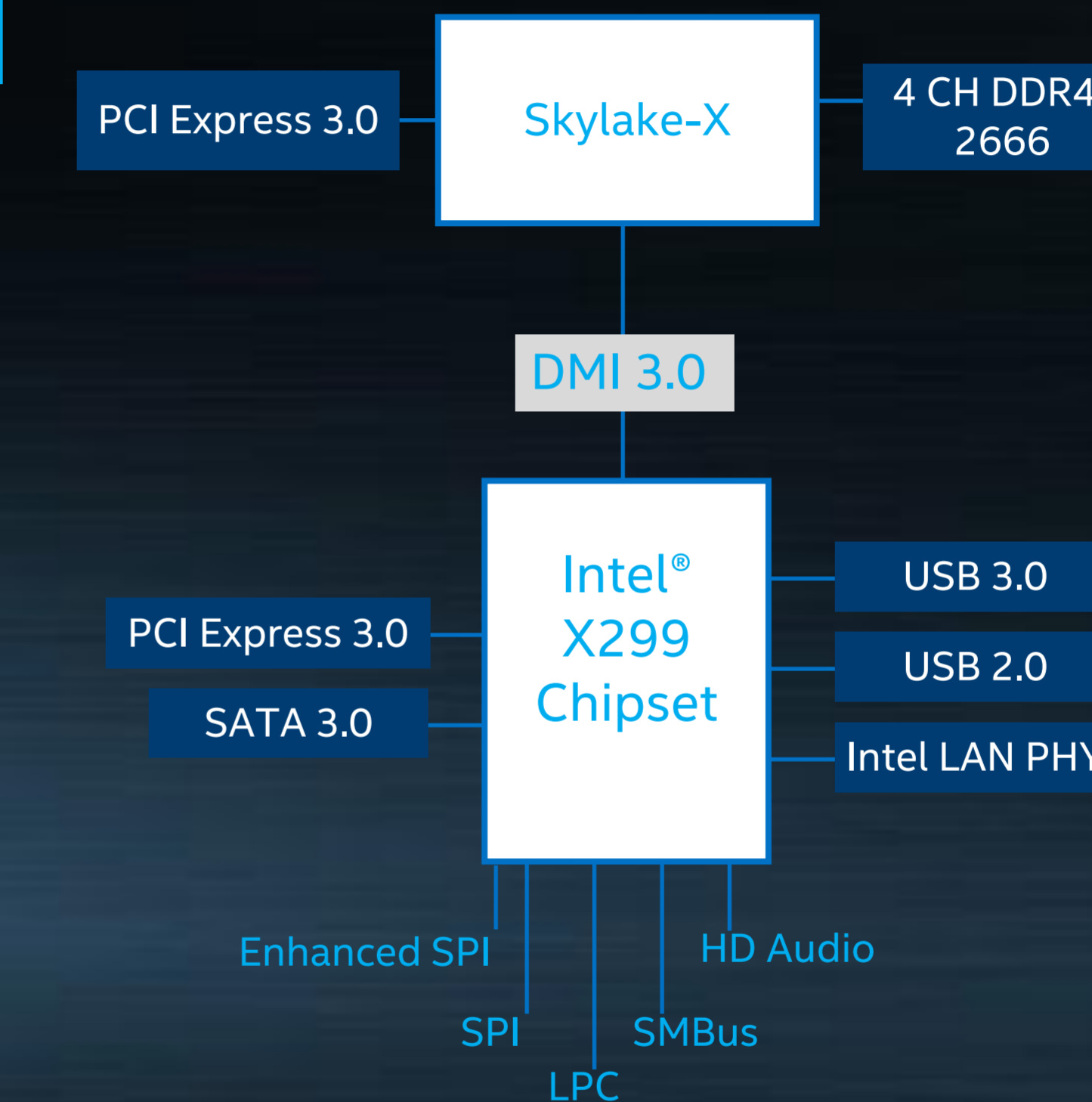



# NEW INTEL® CORE™ X-SERIES PROCESSOR DETAILS

PROCESSOR NUMBER	BASE CLOCK SPEED (GHZ)	INTEL® TURBO BOOST TECHNOLOGY 2.0 FREQUENCY (GHZ) <sup>11</sup>	INTEL® TURBO BOOST MAX TECHNOLOGY 3.0 FREQUENCY (GHZ) <sup>12</sup>	CORES/ THREADS	L3 CACHE	PCIE 3.0 LANES	UNLOCKED <sup>1</sup>	TDP	MEMORY SUPPORT	INTEL® OPTANE™ MEMORY SUPPORT <sup>13</sup>	RCP PRICING (USD 1K)
Intel® Core™ X-series i9-9980XE	3.0	4.4	4.5	18/36	24.75 MB	44	✓	165W	Four channels DDR4-2666	✓	See Pricing Guidance
Intel® Core™ X-series i9-9960X	3.1	4.4	4.5	16/32	22 MB	44	✓	165W	Four channels DDR4-2666	✓	See Pricing Guidance
Intel® Core™ X-series i9-9940X	3.3	4.4	4.5	14/28	19.25 MB	44	✓	165W	Four channels DDR4-2666	✓	See Pricing Guidance
Intel® Core™ X-series i9-9920X	3.5	4.4	4.5	12/24	19.25 MB	44	✓	165W	Four channels DDR4-2666	✓	See Pricing Guidance
Intel® Core™ X-series i9-9900X	3.5	4.4	4.5	10/20	19.25 MB	44	✓	165W	Four channels DDR4-2666	✓	See Pricing Guidance
Intel® Core™ X-series i9-9820X	3.3	4.1	4.2	10/20	16.5 MB	44	✓	165W	Four channels DDR4-2666	✓	See Pricing Guidance
Intel® Core™ X-series i7-9800X	3.8	4.4	4.5	8/16	16.5 MB	44	✓	165W	Four channels DDR4-2666	✓	See Pricing Guidance

Intel® processor numbers are not a measure of performance. Processor numbers differentiate features within each processor family, not across different processor families.  
 All processors are lead-free (per EU RoHS directive July 2006) and halogen free (residual amounts of halogens are below November 2007 proposed IPC/JEDEC J-STD-709 standards)  
 All processors support Intel® Virtualization Technology (Intel® VT-x)



# 2066 SOCKET INTEGRATION NOTES

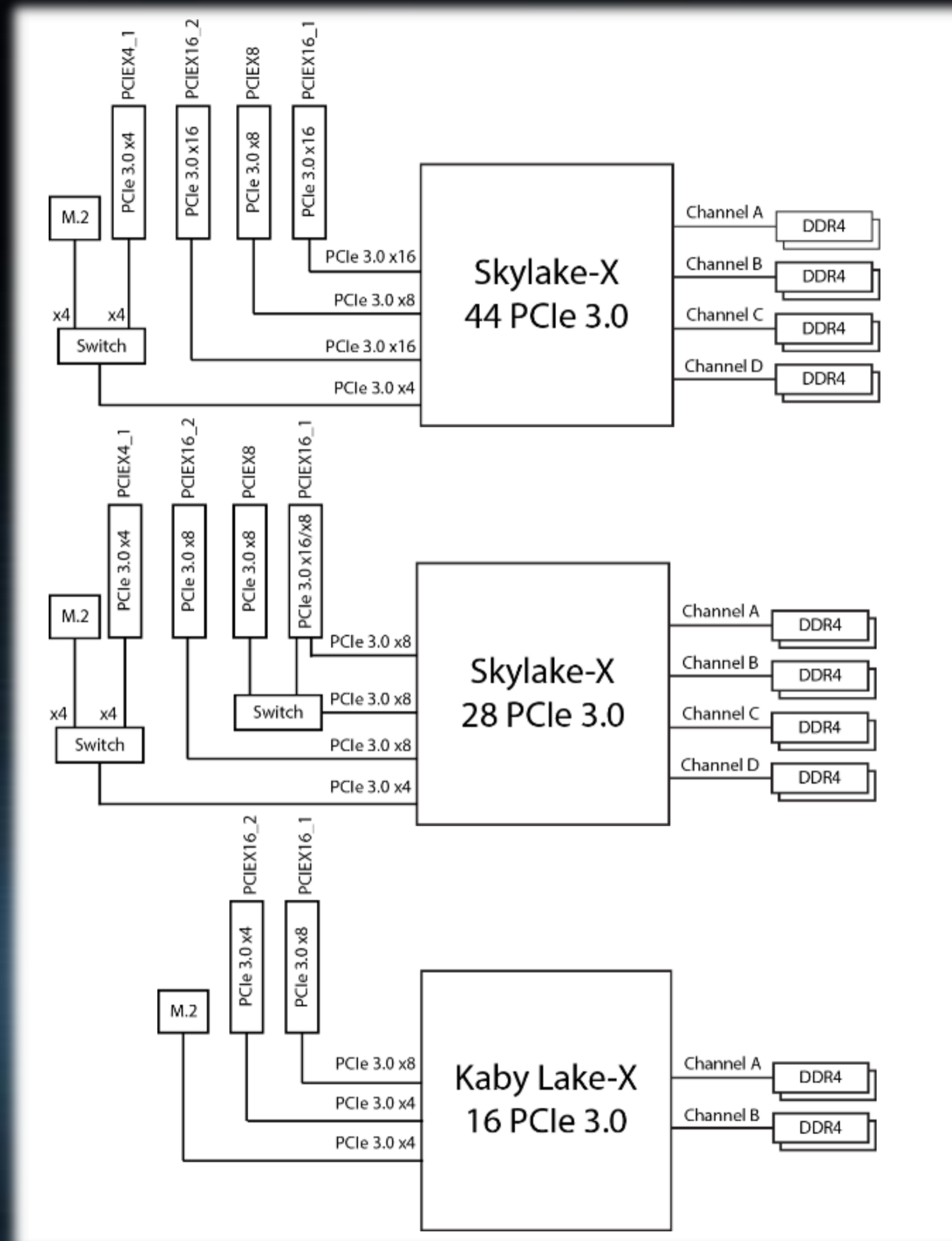

- New socket, same cooling mounting
- Intel® Core™ X-Series processors range from 140W TDP to 165W TDP
- Water cooling recommended
- Need additional power headers
  - 8pin for 140W SCU
  - 8pin+4pin for 160W SCU
  - 8pin+8pin for 160W SCU with overclocking
- PCI-E routing depends on motherboard and CPU (16, 24 or 44 lines)



Intel® Liquid Cooling TS13X

Intel® Core™ X-Series processors range from 112W TDP to 165W TDP. These powerful, scalable processors perform best with premium cooling solutions <sup>(1)</sup>. The following list contains some of the solutions validated by manufacturers that meet specification <sup>(2)</sup>.



[Master Liquid 240](#)  
[Master Liquid Pro 240](#)  
[Master Liquid Pro 280](#)



[EVGA CLC 240](#)  
[EVGA CLC 280](#)



[Kraken X62](#)  
[Kraken X52](#)  
[Kraken X42](#)



[Hydro Series™ H115i](#)  
[Hydro Series™ H110i](#)  
[Hydro Series™ H105](#)  
[Hydro Series™ H80i v2](#)



[EK Extreme Series Kits](#)  
[EK Performance Series Kits](#)  
[EK Gaming Series Kits](#)  
[EK Liquid Series Kits](#)  
[EK Slim Series Kits](#)  
[EK Fluid Gaming Kits](#)



[Water 3.0 Riing RGB 360](#)  
[Water 3.0 Riing RGB 280](#)  
[Water 3.0 Riing RGB 240](#)  
[Water 3.0 Ultimate](#)  
[Water 3.0 Extremev](#)

<sup>1</sup> Links to third-party sites are provided for convenience. Intel Corporation is not responsible for the contents of such linked sites and no endorsement is implied.  
<sup>2</sup> The performance of cooling solutions is dependent on various factors, which can include ambient air temperature; the system components and cooling solution; and the configuration of the system. It is the users' obligation to ensure operation of the processor within the applicable Intel product specifications. See [Ark.intel.com](http://ark.intel.com) for specifications.



**9<sup>TH</sup> GEN INTEL<sup>®</sup> CORE<sup>™</sup>  
DESKTOP PROCESSORS**

**BUILT FOR GAMERS**





# 9TH GEN INTEL® CORE™ : NEW & FEATURED TECHNOLOGY

FIRST 9<sup>th</sup> GEN INTEL® CORE™ i9 DESKTOP PROCESSOR (8C/16T)

UP TO 5.0 GHz AND 16 MB CACHE

SOLDER THERMAL INTERFACE MATERIAL (STIM)

COMPATIBLE WITH NEW INTEL® Z390 CHIPSET  
AND ALL INTEL® 300 SERIES CHIPSETS

UP TO 40 PLATFORM PCIE LANES

INTEL® OPTANE™ MEMORY AND INTEL® OPTANE™ SSD SUPPORT

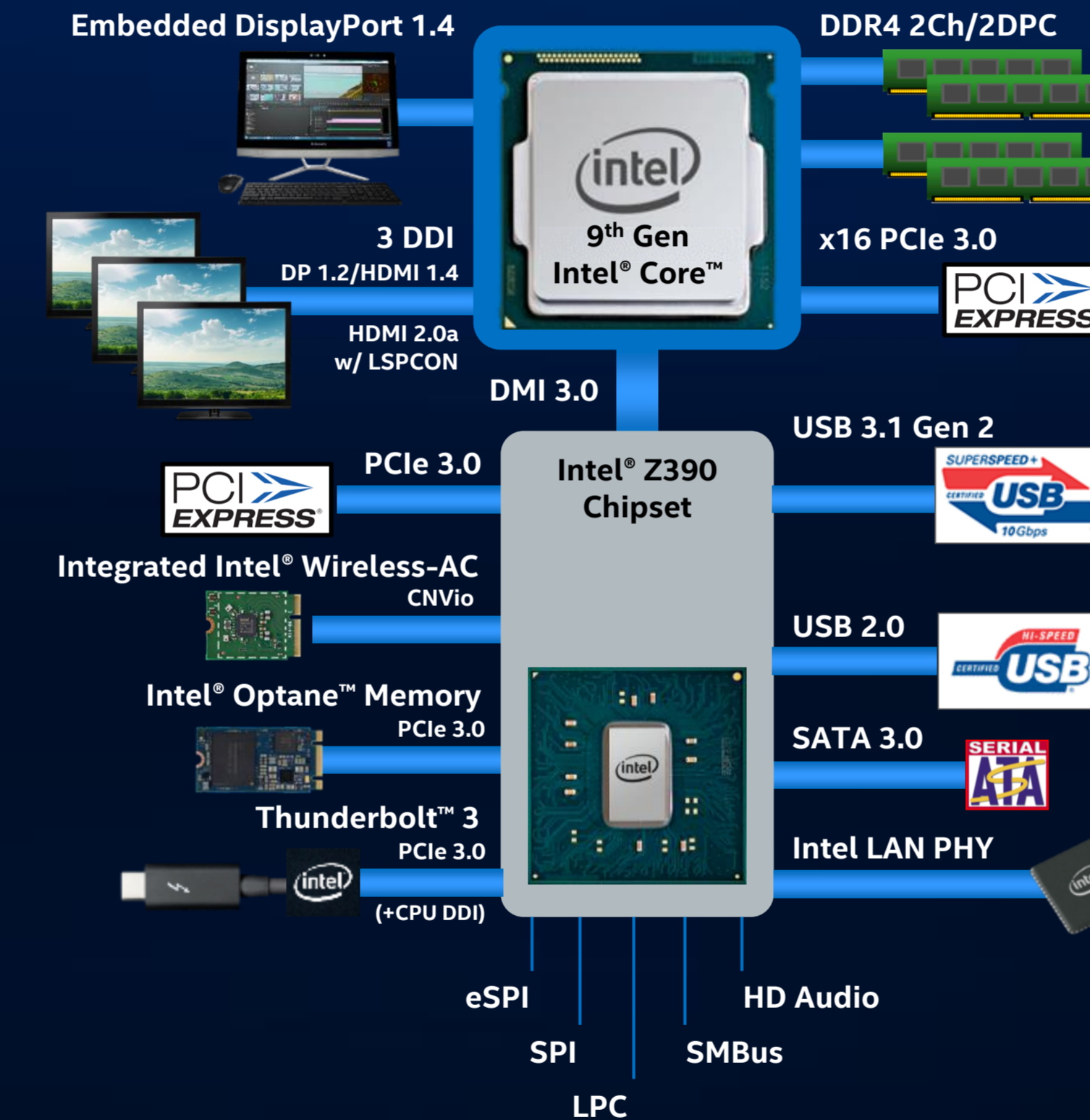

## Platform Details

Socket:

- LGA 1151

Power:

- Enthusiast: 95W
- Corporate/Mainstream: 65W
- Low Power: 35W

Platform I/O Support:<sup>1</sup>

- Up to 46 platform high-speed I/O lanes
- Up to 30 chipset high-speed I/O lanes with port flexibility:
  - Up to 24 chipset PCIe\* 3.0 lanes
  - Up to 10 USB 3.1 ports with up to 6 ports USB 3.1 Gen 2 (10 Gb/s)
  - Up to 6 SATA 3.0 ports
- Intel® Rapid Storage Technology 16
  - PCIe 3.0 x4 storage support
  - CPU-attached Intel PCIe storage



# 9TH GEN INTEL® CORE™ DESKTOP PROCESSOR DETAILS

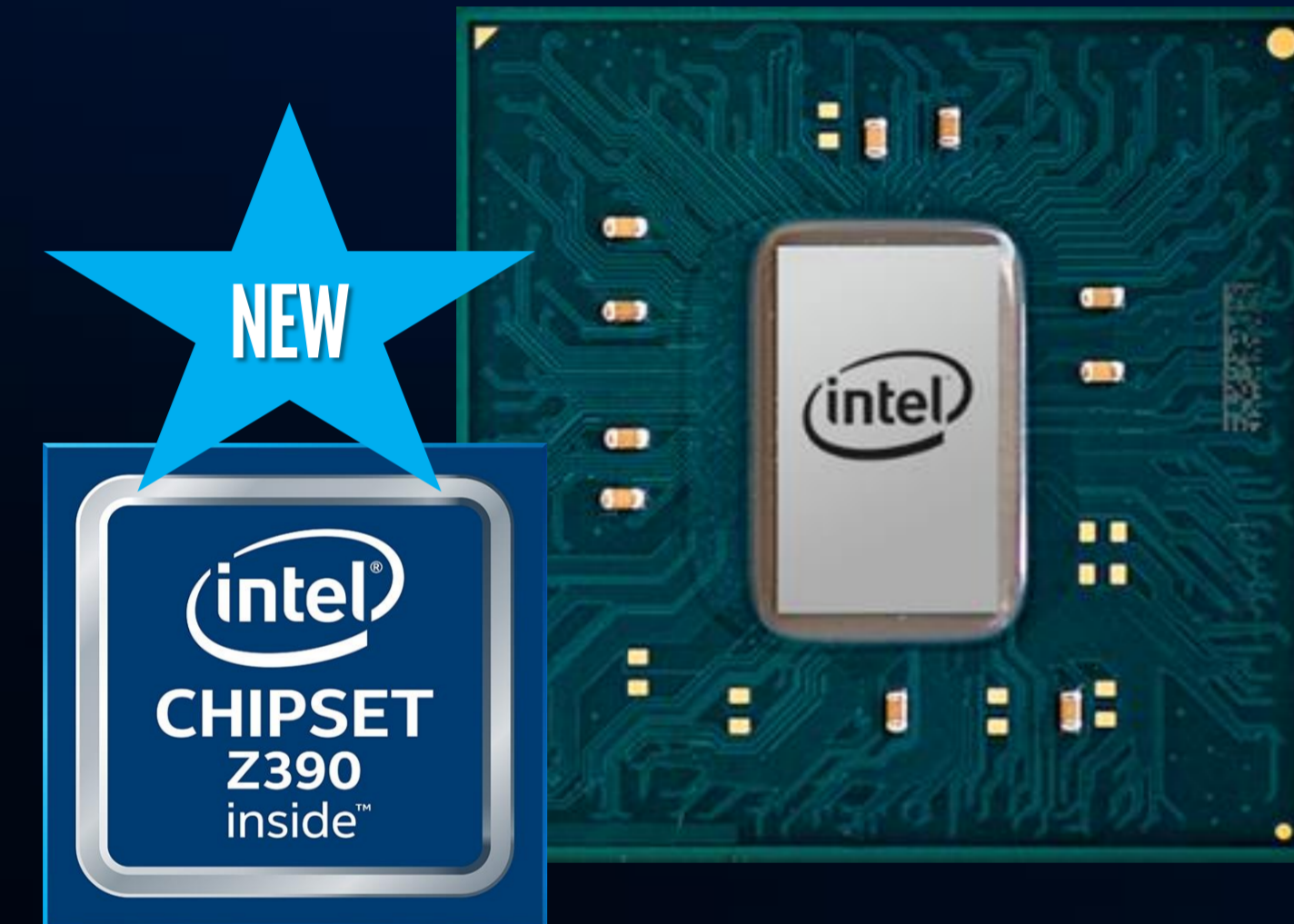

PROCESSOR NUMBER	BASE CLOCK SPEED (GHZ)	INTEL® TURBO BOOST TECHNOLOGY 2.0 MAXIMUM SINGLE CORE TURBO FREQUENCY (GHZ)	CORES/ THREADS	TDP	INTEL® SMART CACHE	UNLOCKED <sup>4</sup>	PLATFORM PCIE LANES	MEMORY SUPPORT	INTEL® OPTANE™ MEMORY SUPPORT <sup>6</sup>	RCP PRICING (USD 1K)
9 <sup>th</sup> Gen Intel® Core™ i9-9900K	3.6	5.0	8/16	95W	16 MB	✓	Up to 40	Two channels DDR4-2666 <sup>5</sup>		\$488
9 <sup>th</sup> Gen Intel® Core™ i7-9700K	3.6	4.9	8/8	95W	12 MB	✓	Up to 40	Two channels DDR4-2666 <sup>5</sup>		\$374
9 <sup>th</sup> Gen Intel® Core™ i5-9600K	3.7	4.6	6/6	95W	9 MB	✓	Up to 40	Two channels DDR4-2666 <sup>5</sup>		\$262

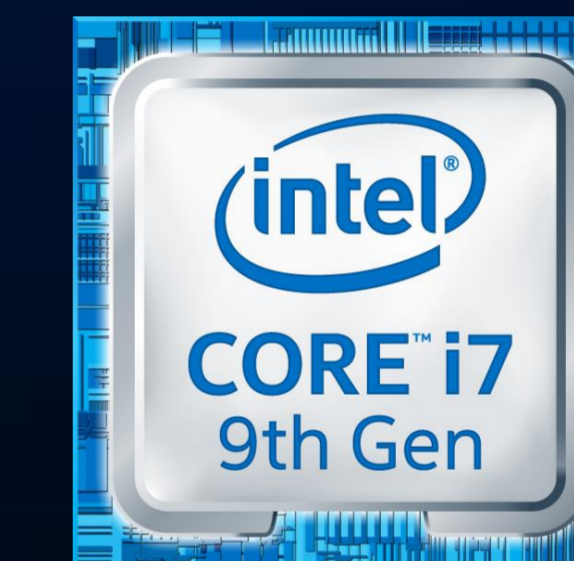

Intel® processor numbers are not a measure of performance. Processor numbers differentiate features within each processor family, not across different processor families.  
 All processors are lead-free (per EU RoHS directive July 2006) and halogen free (residual amounts of halogens are below November 2007 proposed IPC/JEDEC J-STD-709 standards)  
 All processors support Intel® Virtualization Technology (Intel® VT-x)  
 \*Other names and brands may be claimed as the property of others.

The new desktop processors include protections for the security vulnerabilities commonly referred to as "Spectre," "Meltdown" and "L1TF." These protections include a combination of the hardware design changes we announced earlier this year as well as software and microcode updates.

- Speculative side channel variant Spectre V2 (Branch Target Injection) = Microcode + Software
- Speculative side channel variant Meltdown V3 (Rogue Data Cache Load) = Hardware
- Speculative side channel variant Meltdown V3a (Rogue System Register Read) = Microcode
- Speculative side channel variant V4 (Speculative Store Bypass) = Microcode + Software
- Speculative side channel variant L1 Terminal Fault = Hardware



# GET PERFORMANCE WITH INTEL® OPTANE™ MEMORY



## Performance Comparison

	1TB HDD	256GB SATA SSD <sup>8</sup>	1TB HDD + 16GB Intel® Optane™ Memory	1TB HDD + 32GB Intel® Optane™ Memory
<b>SYSmark* 2014 SE Overall Score<sup>1,3</sup></b> (Higher is better)	1X	Up to <b>28% FASTER</b>	Up to <b>28% FASTER</b>	Up to <b>31% FASTER</b>
<b>SYSmark* 2014 SE Responsiveness Subscore<sup>3,4</sup></b> (Higher is better)	1X	Up to <b>2X MORE RESPONSIVE</b>	Up to <b>2X MORE RESPONSIVE</b>	Up to <b>2.1X MORE RESPONSIVE</b>
<b>Storage Performance<sup>2,3</sup></b> (Higher is better)	1X	Up to <b>8X FASTER</b>	Up to <b>14X FASTER</b>	Up to <b>21X FASTER</b>
<b>Device Latency<sup>5</sup></b> (Lower is better)	~10,000µs <sup>5</sup>	~120-150µs <sup>5</sup>	~8µs <sup>6,7</sup>	~7µs <sup>6,7</sup>

1) SYSmark 2014 SE Overall Score  
 2) PCMark\* Vantage (HDD Suite)  
 3) Normalized to 1TB DT HDD 8GB DDR  
 4) SYSmark 2014 SE (Responsiveness Subscore)  
 5) Latency based off of Intel estimates, actuals vary by device  
 6) Intel® Optane™ Memory Product Specification  
 7) For end user workloads that do not fit in the cache expect the HDD latency of 10,000µs  
 8) Intel 480GB 540s SATA SSD used as proxy

Software and workloads used in performance tests may have been optimized for performance only on Intel® microprocessors. Performance tests, such as SYSmark\* and MobileMark\*, are measured using specific computer systems, components, software, operations, and functions. Any change to any of those factors may cause the results to vary. You should consult other information and performance tests to assist you in fully evaluating your contemplated purchases, including the performance of that product when combined with other products. For more information, go to [www.intel.com/benchmarks](http://www.intel.com/benchmarks).

- See Appendix for additional configuration and workload details
- All testing done internally by Intel
- \*Other names and brands may be claimed as the property of others



**INTEL® NUC**





# INTEL® NUC ENTHUSIAST [HADES CANYON]



Unlocked & VR Capable – 100W



## NUC8i7HVK

Processor

8th Generation Intel® Core™ i7-**8809G**  
3.1 GHz - 4.2 GHz Turbo, Quad Core,  
8MB Cache, **100W**

Graphics

Radeon™ **RX Vega M GH** graphics,  
1063 MHz – 1190 MHz  
Unlocked and VR-capable

Serious Performance – 65W



## NUC8i7HVK

8th Generation Intel® Core™ i7-**8705G**  
3.1 GHz - 4.1 GHz Turbo, Quad Core,  
8MB Cache, **65W**

Radeon™ **RX Vega M GL** graphics,  
931 MHz – 1011 MHz



## THE BEST VR EXPERIENCES RUN ON INTEL® PROCESSORS

- Today's virtual reality (VR) experiences offer an entirely new level of immersion and interactivity.
- Step into your favorite games and take control in an expansive virtual world with incredible visuals and an immersive, wide field of view.
- The new Intel® Core™ X-Series processor family is VR ready and exceeds minimum specs for Oculus\* and HTC\*.





# INTEL® NUC: CRIMSON CANYON & DAWSON CANYON

Intel® NUC 8 Home, a mini PC with Windows® 10 – NUC8i3CYSM	Intel® NUC 8 Home, a mini PC with Windows® 10 – NUC8i3CYSN
<b>8th Generation Intel® Core™ i3-8121U</b> 2.2 GHz - 3.2 GHz Turbo, Dual Core, 4MB Cache, 15W <b>AMD Radeon™* 540 discrete graphics, 2GB GDDR5 graphics memory</b>	
<b>8GB Dual-channel LPDDR4-2400</b>	<b>4GB Dual-channel LPDDR4-2400</b>

- **Windows 10 Home x64, Intel® Driver & Support Assistant** pre-loaded
- **1TB** SATA3 HDD pre-installed
- **M.2 22x42/80 key M** slot for PCIe x4 Gen3 NVMe / AHCI or SATA3 SSD
- **Intel® Optane™ Memory ready**
- **2x HDMI 2.0b** ports
- **Intel® i219-V** 10/100/1000 Mbps Ethernet
- **Intel® Wireless-AC 9560 soldered-down**, IEEE 802.11ac 2x2 + **Bluetooth v5**, internal antennas
- **2x front USB 3.1** (one charging), **2x rear USB 3.1**, and 2x internal USB 2.0 via header
- Front Consumer Infrared port
- SDXC slot with UHS-I support
- Up to 7.1 multichannel digital audio via HDMI signals
- 3.5mm front stereo headset jack
- Plastic with metal inner frame, replaceable lid, Kensington lock with base security
- 117 x 112 x 52 mm
- 19V<sub>DC</sub> input range, 19V<sub>DC</sub> **90W** power supply with geo-specific AC cords
- Front Panel, CEC, 2x USB2.0 internal headers
- Microsoft Windows\* 10 logo'd, compatible with various Linux distros
- VESA mounting plate included
- Individual retail packaging
- **Three-year Warranty**



Intel® NUC 7 Business, a Mini PC with Windows® 10 Pro – NUC7i5DNKPC	Intel® NUC 7 Business, a Mini PC with Windows® 10 Pro – NUC7i3DNKTC	Intel® NUC 7 Business, a Mini PC with Windows® 10 Pro – NUC7i3DNHNC
<b>7th Generation Intel® Core™ i5-7300U</b> 2.6 GHz to 3.5 GHz Turbo, Dual Core, 3MB Cache, 15W Intel® HD Graphics 620, 300 MHz - 1.0 GHz <b>Intel® vPro™ Technology</b> , Intel® AMT v11.6		<b>7th Generation Intel® Core™ i3-7100U</b> 2.4 GHz, Dual Core, 3MB Cache, 15W Intel® HD Graphics 620, 300 MHz - 1.0 GHz
<b>Intel Wireless-AC 8265 vPro™</b> M.2 22x30 card 802.11ac 2x2 + BT 4.2, internal antennas		<b>Intel Wireless-AC 8265</b> M.2 22x30 card 802.11ac 2x2 + BT 4.2, internal antennas
<b>TPM 2.0</b>		None
115 x 111 x 36 mm		115 x 111 x 52 mm
1x internal USB 3.0 header (host & device modes)		<b>Speaker and microphone</b> 3.5mm audio jacks <b>Additional USB 3.0 port</b>
<b>8GB (2x 4GB) DDR4-2133 SODIMMs pre-installed</b> (1.2V, dual-channel, 32GB maximum)		<b>4GB DDR4-2133 SODIMM pre-installed</b> (1.2V, dual-channel, 32GB maximum)
<b>256GB Intel® SSD E 6100p pre-installed, M.2 NVMe</b>	<b>128GB Intel® SSD E 5100s pre-installed, M.2 SATA3</b>	<b>1TB HDD pre-installed, 2.5" SATA3</b> (M.2 22x80 slot available for SSD or Intel® Optane™ Memory)

- **Windows 10 Pro\* x64 with platform drivers pre-installed**
- **Dual HDMI 2.0a** (4K 60Hz, HDR), w/HDCP2.2 and basic CEC built-in for 1 port
- **Intel® i219-LM** 10/100/1000 Mbps RJ45 Ethernet
- 2x front USB 3.0, 2x rear USB 3.0, 1x internal USB 3.0 header (host & device modes)
- 2x internal USB 2.0 headers (all USB ports w/ individual power control)
- Up to 7.1 multichannel (or dual 8-channel) digital audio via HDMI
- Aluminum and plastic chassis, replaceable lid, Kensington lock with base security
- Front Panel (with Vcc5/1A, 5Vsby2A, 3.3Vsby1A), RS232, HDMI CEC headers
- 12 – 24V<sub>DC</sub> input range, 19V<sub>DC</sub> 65W power supply with geo-specific AC cords
- Microsoft Windows\* 10 (logo'd), Windows 10 IOT Enterprise, Windows Server 2016
- Supports Ubuntu 16.04 LTS, compatible with various Linux distros
- **Qualified for 24x7 operation**
- VESA mounting plate included
- Individual brown-box packaging
- **Three-year Warranty**





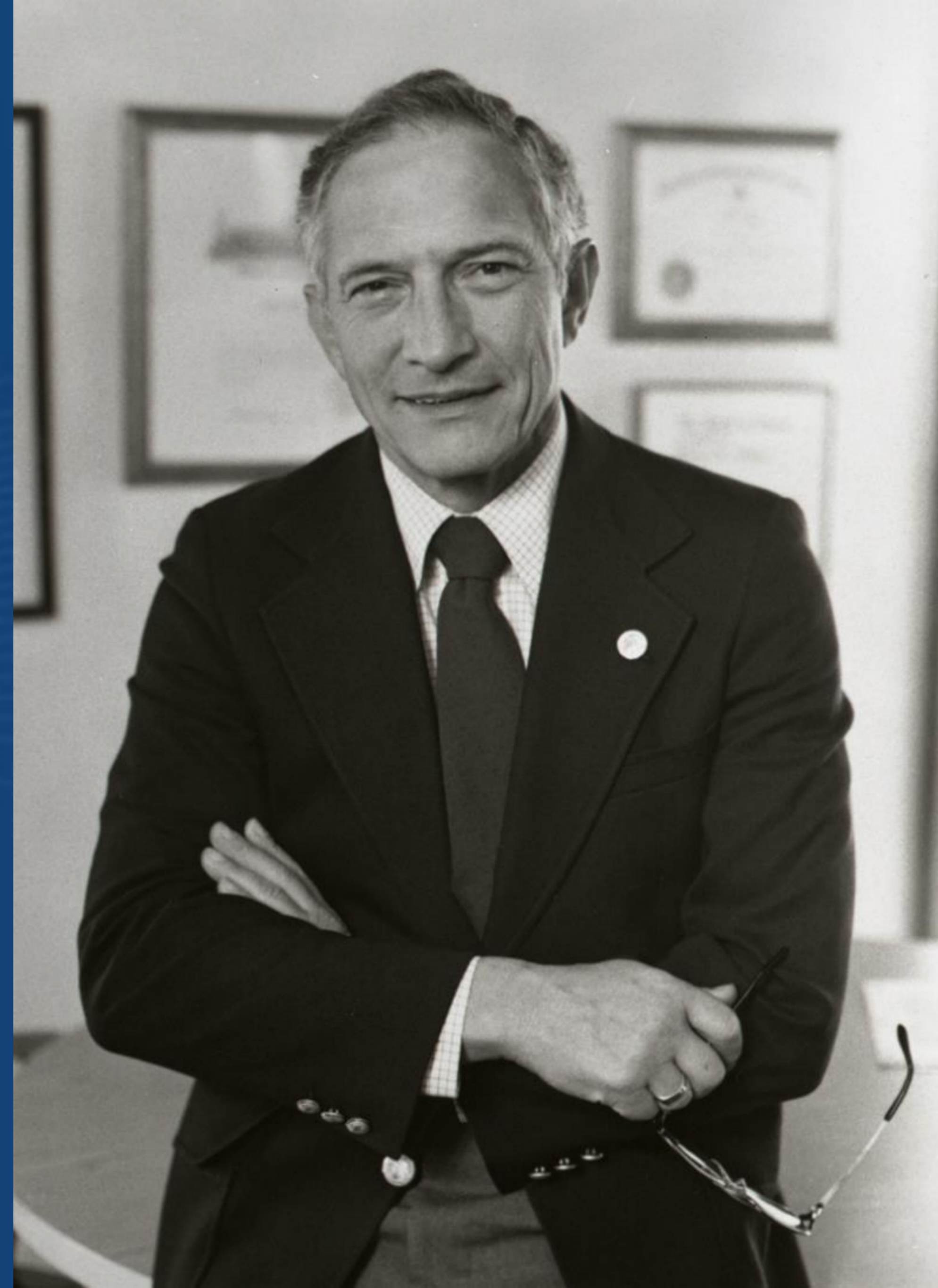

*Не ограничивай себя историей.  
Иди вперед и создавай новое.*

*– Роберт Нойс*

**INTEL® INNOVATION DAY**